

THOMPSON VACUUM PRESSURE UNITS

TTI-2020-DS 20" QUICK OPENING DOME ASSEMBLY

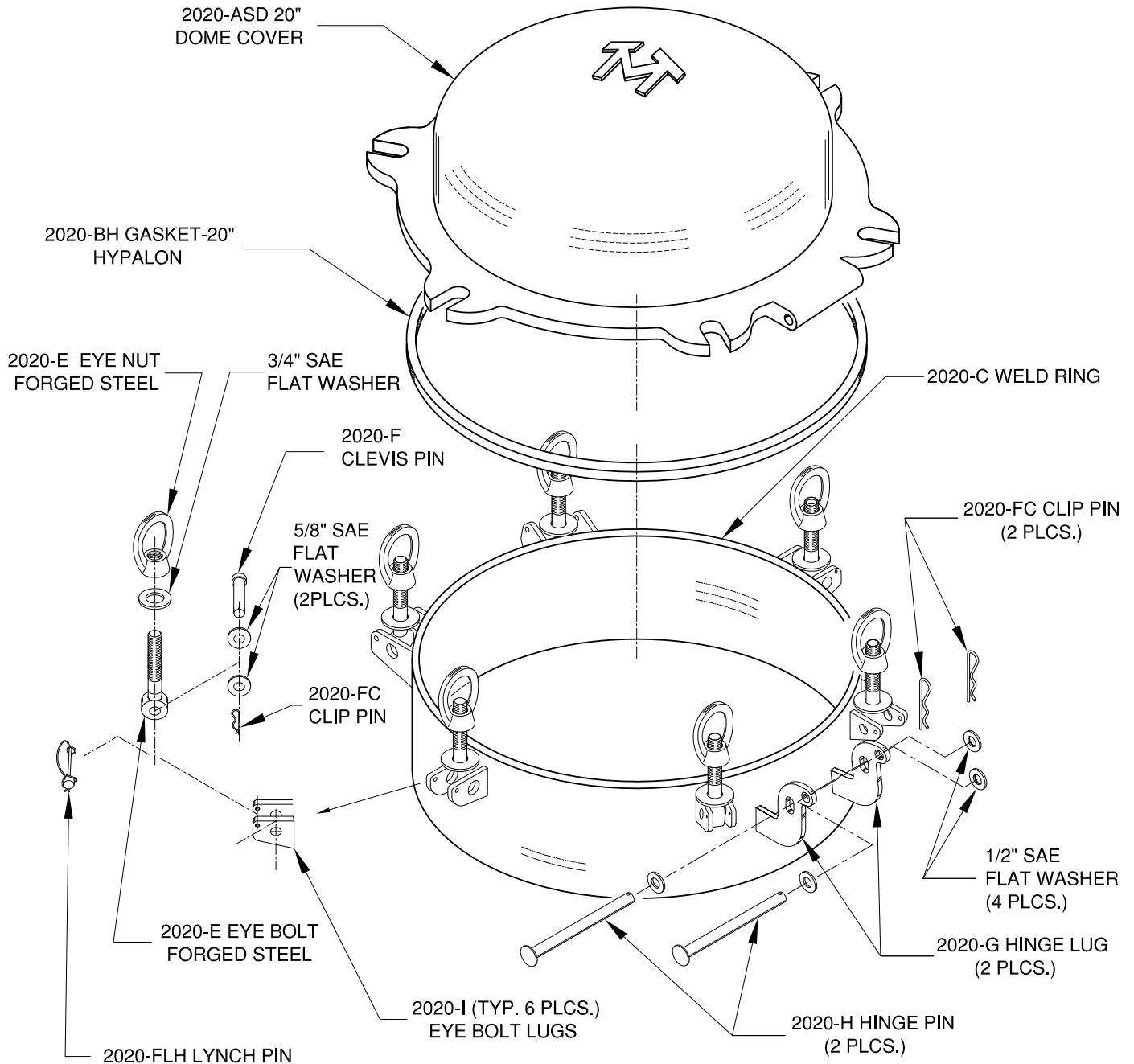

ASME 50# DESIGN PRESSURE AND FULL VACUUM
SHIPPING WEIGHT (APPROX.) 175 LBS.

THOMPSON TANK, INC.

P.O. BOX 790 • LAKEWOOD, CA 90714-0790 • TEL: (800) 421-7545 • FAX: (562) 869-7214

www.thompsontank.com



Thompson Units are manufactured under U.S. Patent No. 3315611, 3347263, 3398513 and 3971400 Patented Canada 1969

©Reg. U.S. Pat. & TM Off.