

# THOMPSON VACUUM PRESSURE UNITS

## TTI-2020-WS 20" QUICK OPENING WASHOUT ASSEMBLY

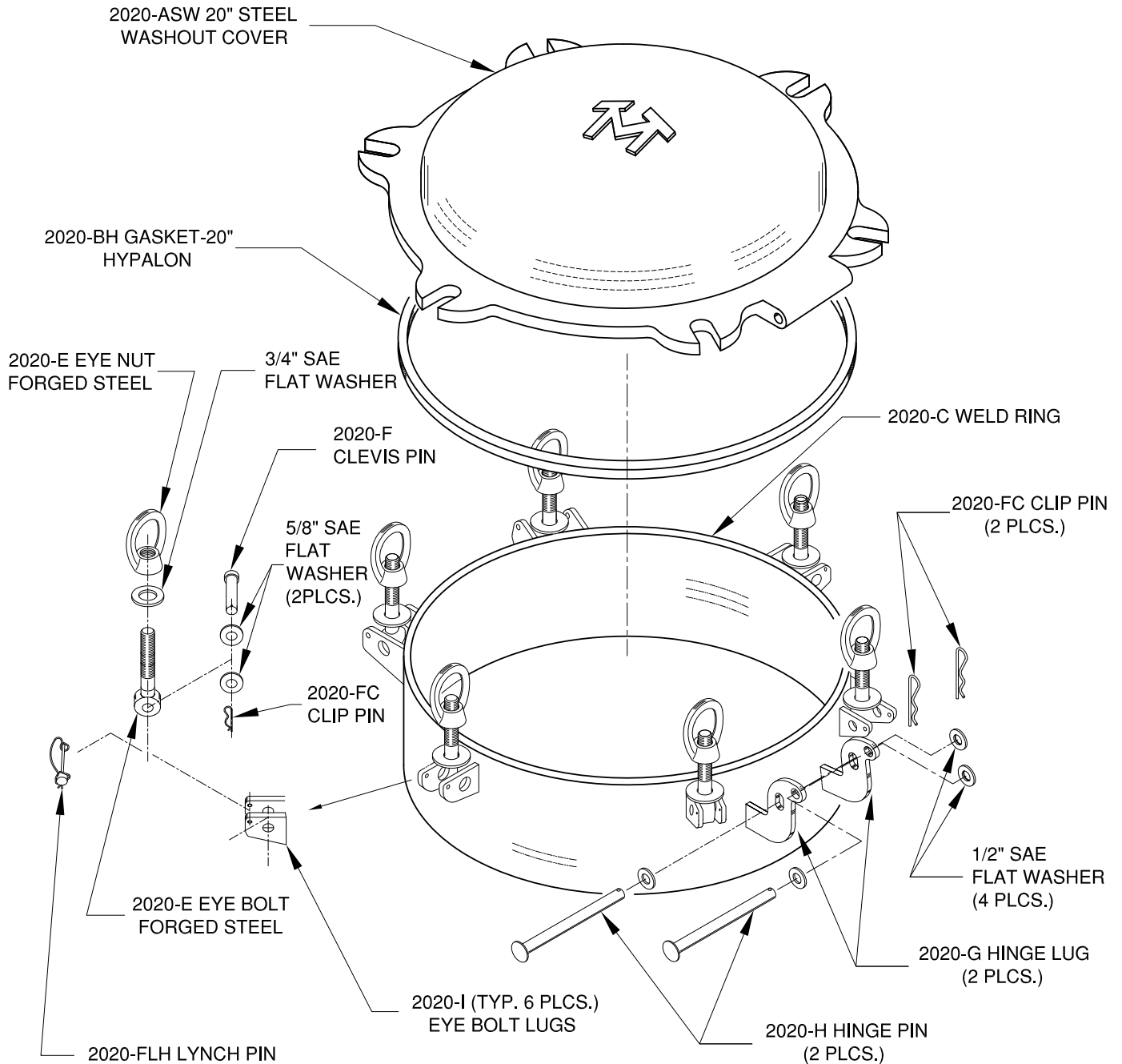

ASME 50# DESIGN PRESSURE AND FULL VACUUM  
SHIPPING WEIGHT (APPROX.) 175 LBS.

**THOMPSON TANK, INC.**

P.O. BOX 790 • LAKEWOOD, CA 90714-0790 • TEL: (800) 421-7545 • FAX: (562) 869-7214

[www.thompsontank.com](http://www.thompsontank.com)



Thompson Units are manufactured under U.S. Patent No. 3315611, 3347263, 3398513 and 3971400 Patented Canada 1969

©Reg. U.S. Pat. & TM Off.